



0-441-69 - Dash Mounted Amber Warning Lamp (ECE R65 Class 2)

Durite LED AMBER Warning Dash Light with strong suction mount. IP67. Fly lead 3M with cigarette plug. UKCA CE, E Marked R65 (class 2), R10 EMC.

Operation Note:

Momentarily press the pattern switch button to change the flash pattern, once for next pattern.
Touch and hold for 5 seconds to reset to FP#1 (Single Flash R65 Class 2).



TECHNICAL SPECIFICATIONS

Type	Dash Mount Amber LED Warning Lamp
Voltage	10-30VDC
LED's	6 x 4W
Power	24W Max
Current Draw	1.32A @ 12VDC, 0.66A @ 24VDC
Flash Patterns	20
IP Rating	IP67
Material Construction	PC Lens, Aluminium Housing
Weight	0.428Kg
Dimensions	Please see below
Operating Temperature	-40°C to +65°C
Storage Temperature	-20°C to +65°C
Certificate	UKCA, CE, E Mark R65 Class 2, R10 EMC,

TECHNICAL DRAWING / FLASH PATTERNS

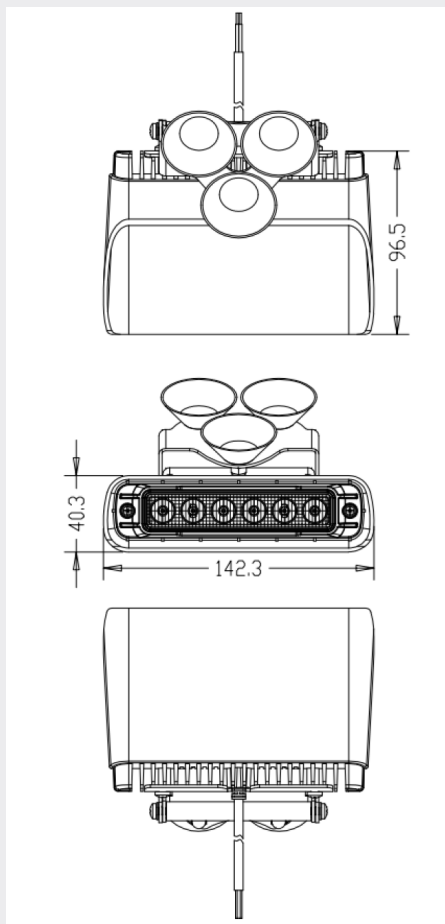

Pattern	Flashing Mode	FPM
1	Single flash, ECE R65 Class 2 (by day)	150
2	Single flash, ECE R65 Class 1 (by night)	150
3	Double Flash	150
4	Quadruple Flash	150
5	Quintuple Flash	150
6	Strobe	1500
7	Combination 1	/
8	Combination 2	/
9	Single Flash, California Title 13	75
10	Combination 3	/
11	Alternate Single Flash	300
12	Alternate Double Flash	300
13	Alternate Quadruple Flash	300
14	Alternate Quintuple Flash	300
15	Alternate Strobe	35
16	Combination 4	/
17	Combination 5	/
18	Combination 6	/
19	Left Double Flash/Right Single Flash	/
20	Cruise (30% brightness by night)	/